



## Table of Contents

Introduction -----	1
Intended Applications -----	1
Safety Precautions -----	1
Symbols Key -----	3
Product Specifications -----	4
Exterior Descriptions -----	5
Pre-start Procedures -----	7
Initial Operation -----	9
Standard Operating Procedures -----	10
Moisture Control -----	11
Pause Operations -----	12
Shutdown Procedures -----	12
Freeze Prevention -----	13
Maintenance -----	15
Safety Features -----	22
Troubleshooting Guide -----	24
Optional Items -----	29

## Introduction

The steam unit represents the future of environmentally friendly and effective curing. Safe, durable and easy to use, the steam unit will support your during operations for many years to come.

## Intended Applications

The steam unit is designed for curing of resin impregnated Liner with maximum temperatures reaching at 135 °C (275 °F).

## Safety Precautions



Before operating the steam unit for the first time, read the manual completely.

The manufacturer and distributors are not liable for the mechanical troubles, property damage, or personal injury caused by the operator(s) unfamiliarity with the manual's instructions.







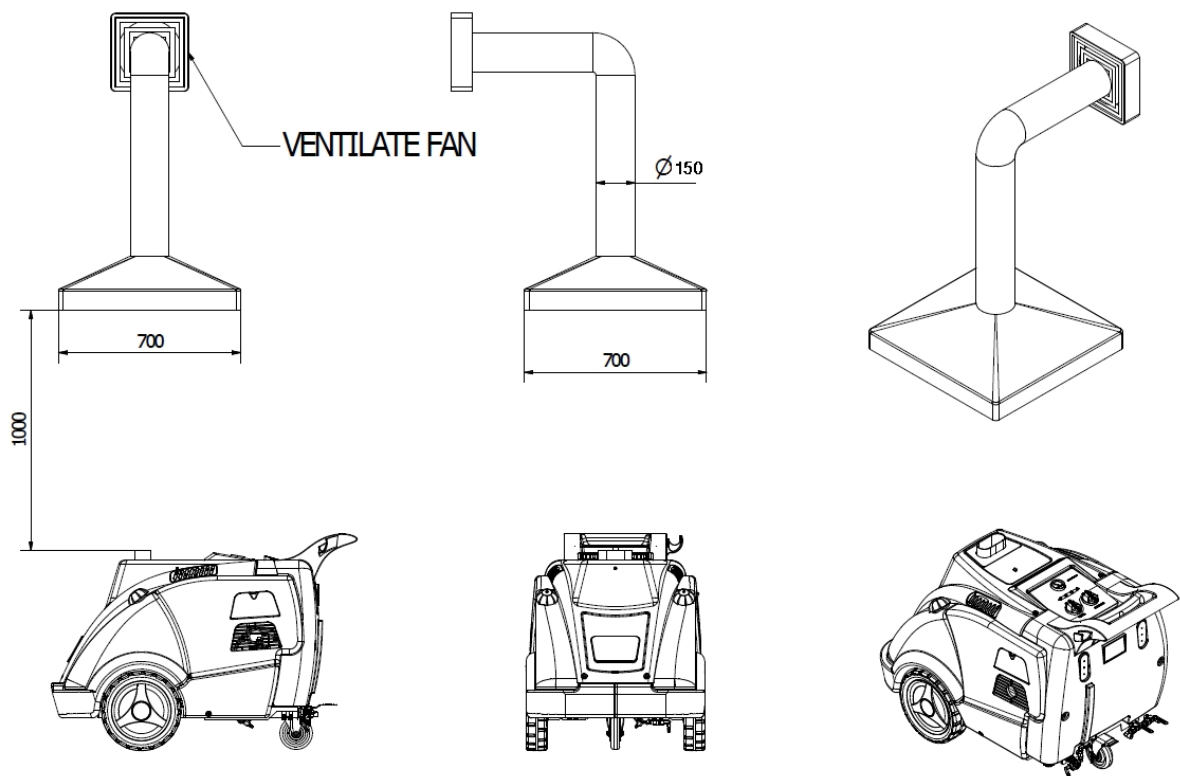







- With regards to the steam vessel, use only water and the manufacturer's recommended steam vessel cleansing solution. Do not put any other chemicals or detergents into the water tank or steam vessel.
- Do not use distilled water or filtered water under 15 ppm
- "Soft" water is recommended. Otherwise, use only clean tap water with anti-scaling solution.
- Use only clean diesel.
- Provide adequate electrical power requirements accordingly to the specifications.
- Make sure that all the switches on the machine are off before plugging the machine into an electrical outlet.
- If an extension cord is used, make sure it is constructed waterproof and of proper diameter based on the cord length and required electrical specifications.
- Turn off the POWER (EMERGENCY STOP) and STEAM switches when refilling the fuel tank.
- Turn off and unplug the machine from its power source and allow the steam unit to cool down before carrying out any maintenance.
- Use only hoses and all other accessories recommended by the manufacturer. Use manufacturer approved spare parts only.
- Use and store the steam unit on a leveled up surface only.
- Do not use the machine in rain or snow outdoors. The steam unit is not weather-proof or water-proof.
- Never leave the machine unattended while in use.
- Never store the machine below 0 °C (32 °F) or extremely cold weather condition.
- In cold climates, do not allow water to sit when the steam unit is not in use. Do not operate the machine if any parts are frozen or suspected of being frozen.  
(See "Freeze Prevention on page13)
- Do not use the steam unit if any part, power cord, safety device, hose is visually damaged or suspected of being damaged.
- Use proper ear, eye and hand protection when operating the Optima. Noise can be generated from steam pressure and it can be reach 95 decibels (dB).
- Do not use the machine within the range of people who are not wearing any protective gears.
- Do not direct the steam jet spray, aim or discharge at itself, live electricity, people or animals.

- The machine is not to be used by children or persons with reduced physical, sensory or mental capabilities, or lack of experience and knowledge, unless they have been given supervision or instruction.
- Keep the steam unit away from children and animals at all times.
- Children should be supervised to ensure that they do not play with the machine.
- Never disable a sensor in order to bypass an alarm.
- To provide continual protection against risk of the electric shock, connect properly to grounded outlets only.
- The exhaust is very hot. Take precautions when operating the steam unit within a confined space or indoors.
- Provide proper ventilation for steam unit. The steam unit is oil-heated appliances.

[Example of Recommended Ventilation Set-up]











## Symbols Key

	Do not direct the steam jet at people, live electricity, animals, etc.		Read the manual.
	Warning: risk of burns.		Water pump run.
	Fuel (diesel only).		Warning: risk of electric shock.
	Feed-Water.		Caution
	Water supply connection.		Ground
	Pressure gauge		Main Power
	Thermistor		Steam jet

## LED Light Indication

○ off    ☀ Blinking    ● Solid    ● Solid or off    🔊 Alarm beeps once    🔊 Alarm beeps continuously

	Main Power on	
	Water pump run on	
	Flame error on	
	Low water level detection error on	
	Alarm beeps once	

## Product Specifications

Working Pressure	7~8.5 bar / Max 9.5 bar (101~123 psi / Max 137.7 psi)		
Spraying Temperature	< 135°C (< 275°F)		
Steam Temperature	178°C / Max 200°C (352.4°F / Max 392°F)		
Preheating Time	2 ~ 3 minutes		
Rated Electricity Power	290 Watts (max.)		
Voltage / Hertz	100V~240V, 50 / 60Hz (Customer configuration available)		
Water Tank Capacity	20 ℓ (5.3 gals)	N.A.	
Water Consumption Rate (Max)	300 ~ 1200cc/min (0.08~0.32gpm)		
Fuel Tank Capacity	20 ℓ (5.3 gals)	17 ℓ (4.5 gals)	
Fuel Nozzle	1.10 gallon/hour @ 10.0 bar		
Net Weight (kgs / lbs)	85 kgs (187 lbs)	87 kgs (192 lbs)	93 kgs (205 lbs)
Product Dimensions [L] x [W] x [H]	1090 x 700 x 900 mm (43 x 28.3 x 35.4 inch)		780 x 500 x 760 mm (30.7 x 19.7 x 30 inch)

### Note!

- \* To ensure safety and machine effectiveness, do not modify factory settings for steam pressure and temperature.
- \* Water consumption rate may vary based on the use of the moisture valve and business applications. (See page 11, "Moisture Control").

## Exterior Discription

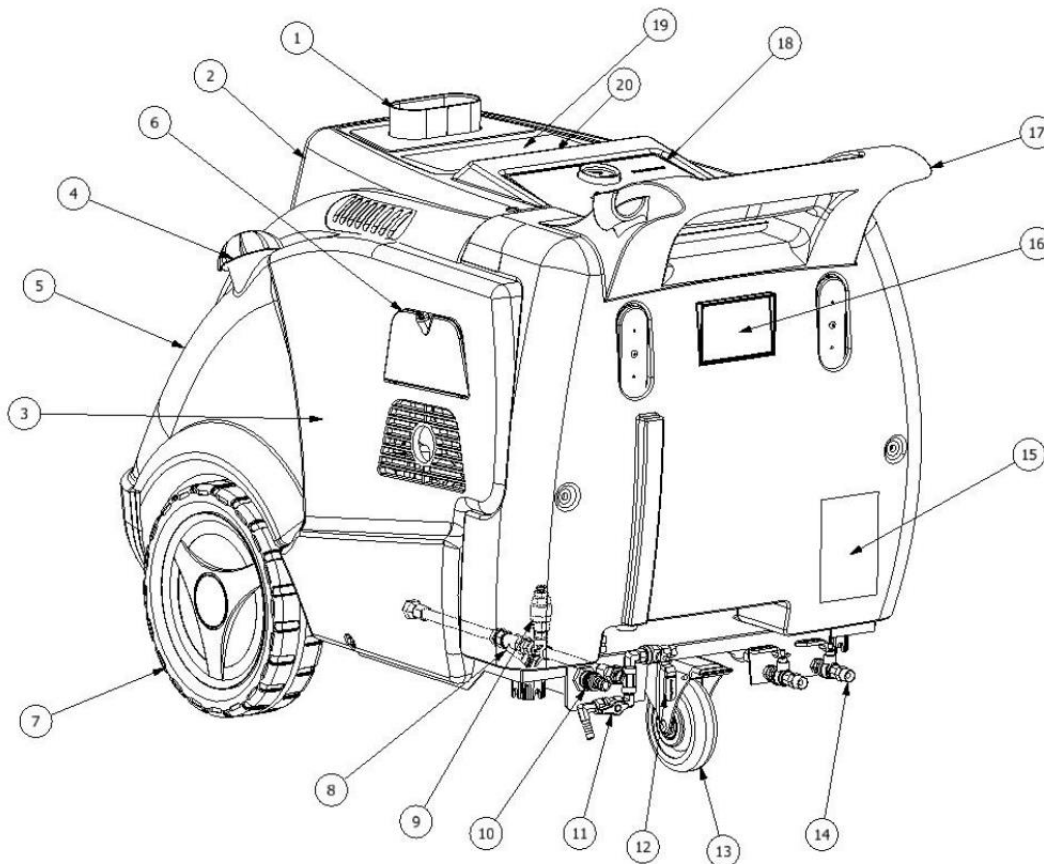

1. Exhaust / flue	11. Drain valve
2. Top cover	12. Moisture control valve
3. Lateral/Side panel	13. Turning wheel with brake
4. Tank cap	14. Steam outlet
5. Water tank	15. Warning sticker
6. Throttle door	16. Specification sticker
7. Front wheel	17. Handle
8. Y-strainer	18. Control box
9. Non-return valve	19. Operating instruction sticker
10. Quick Plug for feed-water (DMF only)	20. LED signal information

## Pre-start Procedure

### Steps:

1. Connect the steam hose and gun to the steam outlet valve. Ensure a tight connection (use tools).

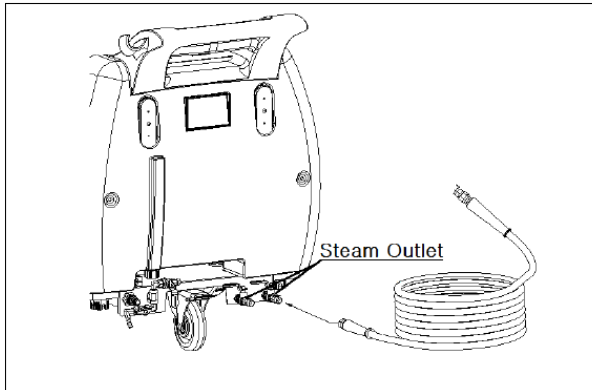

2. Fill the water tank with soft water. When tap water is used, add anti-scaling solution to the water tank as instructed by the supplier. Do not use distilled water.

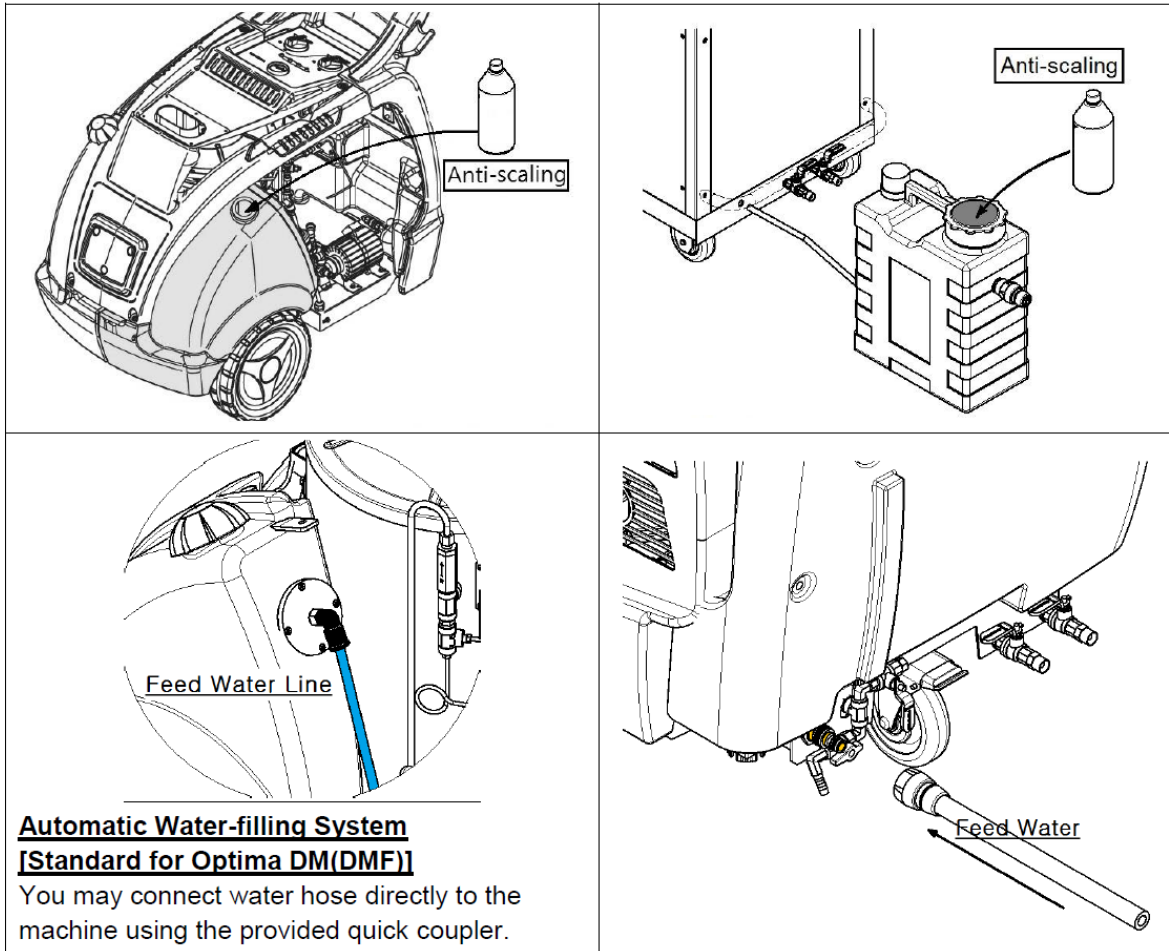

## Water Quality Matters!

Water quality can greatly affect the steam unit's life span/time and performance. It is important to use **SOFT WATER**. If tap water is used, daily use of water treatment (water softening liquid) and regular sediment removal will help ensure efficient operations. (see page 15 "Maintenance A & B" for more information).

**Do not use distilled water. Do not put any other chemicals or detergents into the water tank or steam vessel.** The feed water temperature should be above 5°C (40°F).

### Anti-scaling water treatment

If water other than treated soft water is used, scale will build up on steam vessel walls, probe sensors and pipes. This will adversely affect the performance and lifespan of the machine. In order to prevent this, we recommend operators to use anti-scaling solution. Simply add anti-scaling solution every day and ensure that the steam vessel is drained at the end of the day. This procedure will prevent scale build-up inside steam vessel and increase the thermal efficiency of the machine. Use manufacturer recommended steam vessel anti-scaling solution only.

3. Fill the fuel tank with diesel.



4. Plug the machine into an electrical outlet with all the switches on the machine off. If an extension cord is used, the plug and the socket must be of watertight construction. Inadequate extension cords can cause damage to the machine and can be dangerous to operators.

Refer to: [http://en.wikipedia.org/wiki/Mains\\_electricity\\_by\\_country](http://en.wikipedia.org/wiki/Mains_electricity_by_country).

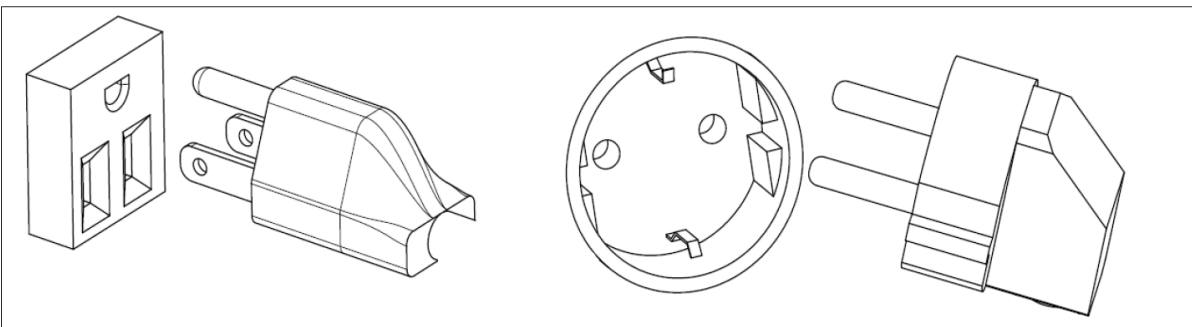



### Note!

When using the steam unit after draining the steam vessel, the above procedure must be repeated.

## Initial Operations

“Initial operation” means operating the machine after draining all water from the steam vessel.  
After completing the pre-start procedure, follow the steps below.

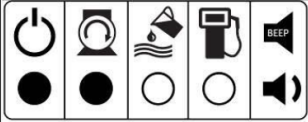
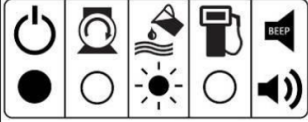
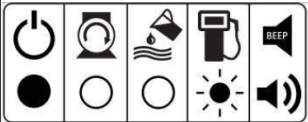
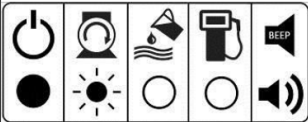
○ off     - Blinking    ● Solid    ◐ Solid or off     Alarm beeps once     Alarm beeps continuously

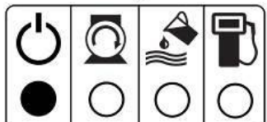
Steps	Instructions / Corrective action	Type	Signal indications
1	Make sure the water tank is full. (If using the auto water filling system, connect water hose to water supply source, i.e. faucet and open the valve) Fill the fuel tank with diesel. Connect the Power cord to the outlet.		
2	Turn on the POWER (EMERGENCY STOP) switch and then turn on the STEAM switch. You will see one of the following signal indications. <b>A:</b> POWER and WATER PUMP RUN lights are on. The water pump supplies water to the steam vessel for about 120 seconds	A	
	<b>B:</b> The POWER light on and WATER TANK light is flashing, and the alarm is going off. This means the float switch in the water tank does not detect water. Add water to the water tank.	B	
	<b>C:</b> The POWER light on and FUEL TANK light is flashing, and the alarm is on. This means the float switch in the fuel tank does not detect fuel. Add diesel to the fuel tank.	C	
3	If the alarm beeps continuously for more than 120 seconds, check on A or B signal indications. <b>A:</b> Water pump runs over 120 seconds at initial steam. Reset the STEAM switch and see the process. <b>B:</b> Insufficient water. Refill the water tank.	A	
		B	
4	When water supply reaches the low water probe sensor, programmed normal steam will begin. You will see 2 lights (POWER & WATER PUMP RUN) on, and then WATER PUMP RUN light will turn off when water reaches the high water probe sensor.		 ↓ 

## Standard Operating Procedures

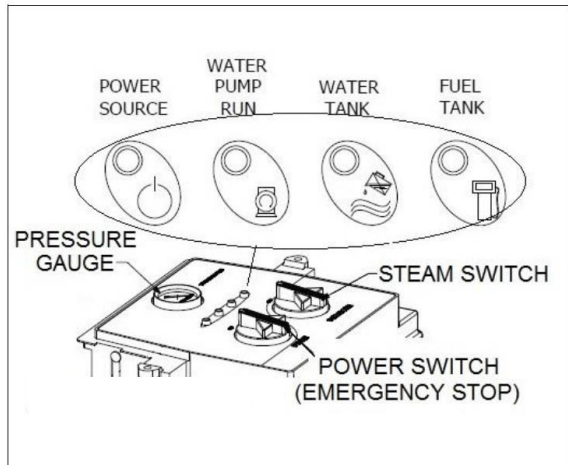

### Steps:

1. Turn on the POWER (EMERGENCY STOP) switch, and then turn on the STEAM switch. If the alarm beeps once and the POWER light is on, the machine is ready to operate.

(If you are starting the steam unit for the first time or using after draining the steam vessel, refer to “Initial Operation” on the previous page.)

2. Once the machine ignites, it will reach the operating steam pressure within 2~3 minutes.

3. After the steam pressure reaches 8.5 bar (123.2 psi), open the steam outlet valve(s) and begin to operate.

**Review all safety precautions on page 1~2. Never leave the machine unattended. The exhaust is very hot. Take precautions when Operating the machine in a confined space.**

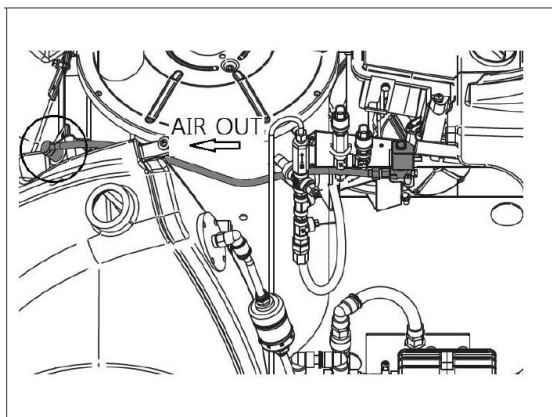

[Automatic air purge system]

The steam unit is equipped with an electronic valve that purges air to avoid false pressure reading of the system. Whenever the thermistor reading is below 100 °C (212 °F), the system assumes that the high pressure in the steam vessel is due to internal air and will open the electronic valve to remove internal air.

## Moisture Control

You can increase the moisture content in the steam by opening the moisture control valve. Increasing the moisture content in the steam increases water consumption and may produce water run-off.

Dry steam may persist due to extremely hot weather; adjust the moisture control valve accordingly. When cleaning and/or sterilizing interior surfaces, ensure that the moisture control valve is closed to minimize surface moisture. Wet steam may persist in extremely humid or cold weather.

### **Note!**

In extremely hot or dry weather conditions, using two spray guns continuously with the moisture control valve open all the way may consume steam faster than what can be replenished. In this case, the alarm will sound. Close the moisture control valve by 1/3 and allow pressure to build.

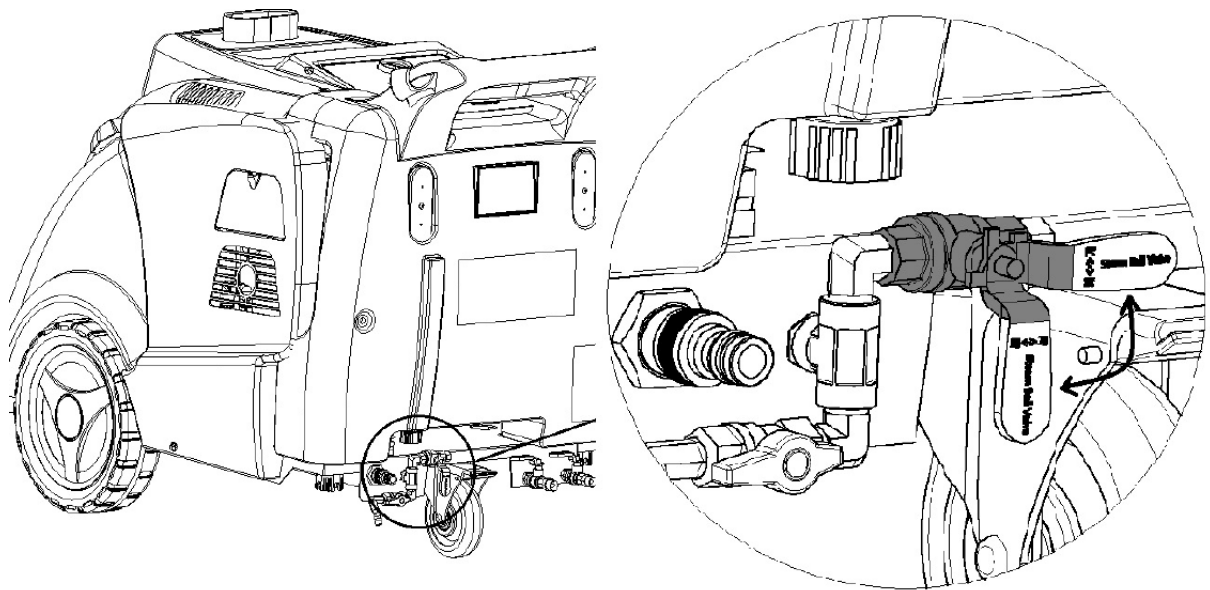

## Pause Operations

(Follow these steps if you intend to stop using steam for more than 5 minutes temporarily.)

### Steps:

1. Turn the STEAM switch off.
2. The blower fan will be shut off automatically after 30 seconds to remove excess fumes.
3. Close the steam outlet valves and pull the steam gun trigger to release any remaining steam in the hoses. This will prevent the release of water (condensed steam) and increase the life span of the steam hoses and guns.

### Note!

When manually refilling the water or fuel tank, turn off the STEAM switch first. After refilling the water or fuel tank, turn the STEAM switch back on and resume operation.

## Shutdown Procedures

### Steps:

1. Turn the STEAM switch off.
2. After 30 seconds, the blower fan will automatically stop. Once the blower fan stops running, turn off the POWER (EMERGENCY STOP) switch.
3. Use up the existing steam in the steam vessel until the pressure drops to 1~2 bar (15~29 psi). Then drain out all water from steam vessel by opening the drain valve. If the water from the steam vessel is milky, open the Y-strainer drain valve (cap) and clean the filter of Y-strainer.
4. Close the steam outlet valve and pull the spray gun trigger to release the remaining steam in the hoses. This will prevent the release of water (condensed steam) at next use and increase the life span of the steam hoses.
5. In cold climates or cold weather condition, additional steps are required to prevent damages. (See "Freeze Prevention" on page 13).

### Tips!

Extend the life span of the steam unit:

1. Use soft water or clean tap water.
2. Use water treatment daily if tap water is used.
3. Always remove steam from hoses, spray guns, and the steam vessel after use.
4. Store the steam unit at room temperature.
5. Remove sediments from the steam vessel regularly. (See "Maintenance" on page 15).
6. Remove hardened scale from the vessel regularly. (See "Maintenance" on page 15).
7. Use only clean diesel. Never use a recycled- diesel or other types of fuel.

## Freeze Prevention

The steam unit can perform in the sub-zero weather. However, it takes precautions for storage. In cold climates it is necessary to store the steam unit in an area where the temperature is above freezing. Unplug the machine from electrical source and follow steps below to protect the steam unit against ruptured lines and damage caused during cold climates.

### Steps:

#### **1. Empty the steam vessel.**

Slowly open the drain valve cap once the pressure is below 2 bar (29 psi). Keep drain valve and Y-strainer drain cap open until next use.

**Warning! : Steam is extremely hot. Wear appropriate hand and eye protection.**

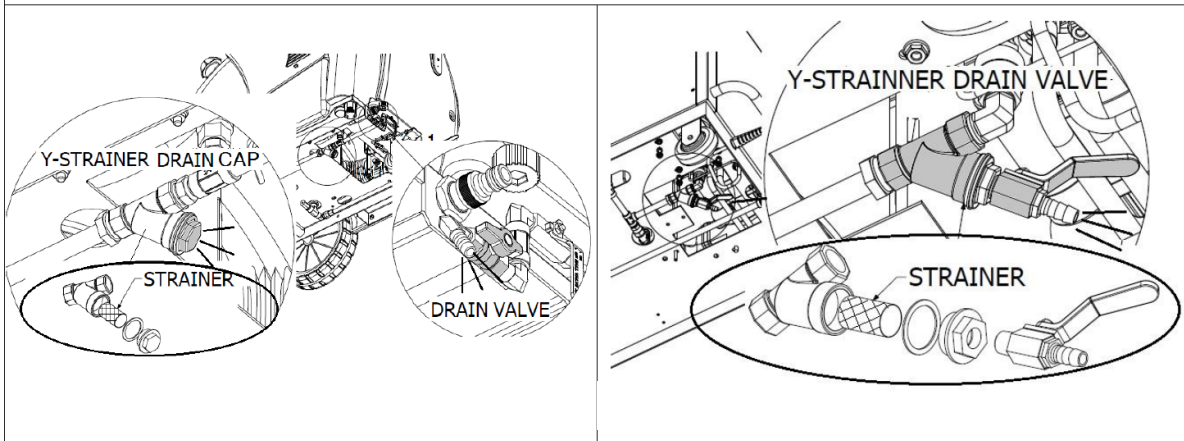

#### **2. Empty the water tank.**

Open the water tank drain cap at bottom side.

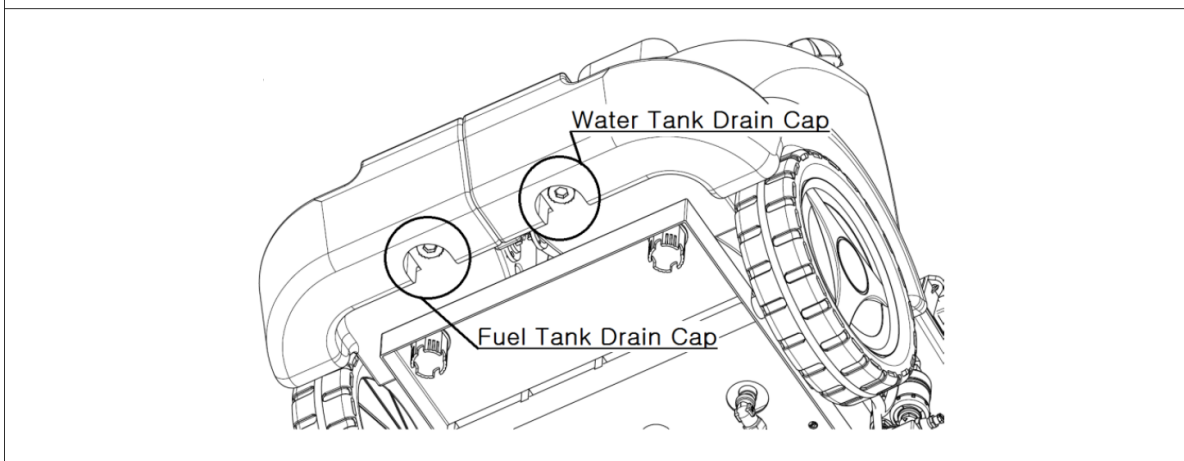

### 3. Drain the water suction lines and the water pump.

Open the drain valve or Y-strainer drain cap; then disassemble / detach water suction line from top of water pump and drain all remaining water using compressed air. Keep drain valve open until next use.

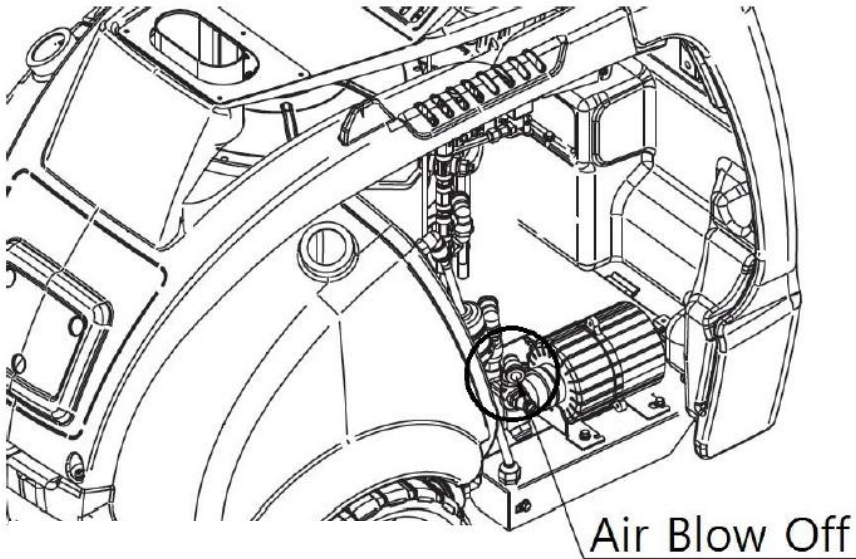

### 4. Store the machine at room temperature.

#### Note!

Doing freeze prevention maintenance can prevent costly repairs. Frozen water can rupture lines, cause malfunctions and destroy parts. Never operate the machine if any part is frozen or suspected of being frozen. Thaw the machine at room temperature overnight. Carefully inspect the machine.

If the machine is visually damaged or performs abnormally, immediately turn off the machine and contact your distributor or manufacturer.

## Maintenance

### Warning!

Unplug the machine from electrical source and allow it to cool off before conducting maintenance. Wear appropriate safety protection.

**Note:** To avoid unexpected downtime, keep up with maintenance schedule.

### Maintenance Schedule

	Maintenance Items	Daily	Monthly	Every 3 months or as needed	Every year or as needed
A	Add water treatment. (Softener)	✓			
B	Check for/drain sediments from steam vessel	✓			
C	Drain water and fuel tank		✓		
D	Check / replace water and fuel filter		✓		
E	*Check/clean water probe sensors		✓		
F	Clean/realign fuel nozzle and electrodes			✓	
G	*Perform steam vessel de-scaling				✓
H	Remove soot in the combustion chamber				✓

\*The frequency of these maintenance items may vary based on the hardness of water in your area.

### A. Add anti-scaling water treatment.

Add the recommended dosage of anti-scaling water treatment into the water tank. Use a TDS meter to determine the hardness of water in your area. (See "Pre-start Procedure" Step #2 Page 7)

#### [Recommended Anti-scaling Water Treatment Dosage]

TDS Meter Reading (ppm)	0 - 40	40 – 120	120 - 425	425 - 1000
Hardness description	Very Soft	Soft	Hard	Very Hard
Dosage per every 100L (27gal) of water	No dose	25ml	50ml	100ml

Scale is caused by dissolved mineral in water settling on internal surfaces. Scale build-up can greatly impact steam vessel longevity and operating efficiency. Adding anti-scaling water treatment will help prevent scale from forming on the inside wall of the steam vessel and protect against sensor malfunctions.

Only add water and manufacturer approved anti-scaling solution to the water tank.

**B. Check for/drain sediments from steam vessel.**

Open the drain valve and check the color of the water. If the water is milky, drain all remaining water from the steam vessel by opening the Y-strainer drain valve or cap.

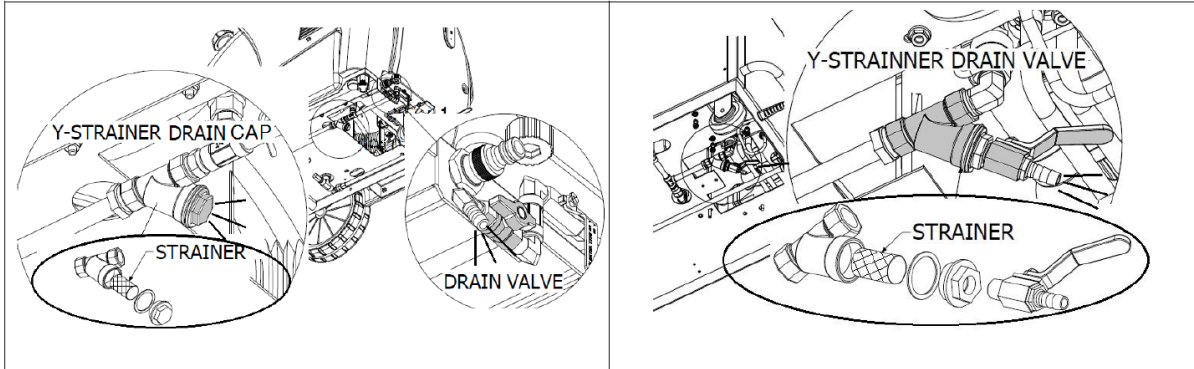

**C. Drain the water & fuel tank**

Drain water and fuel tanks by removing the drain caps from both tanks. This will flush out sediments which may have settled to the bottom of the fuel and water tanks.

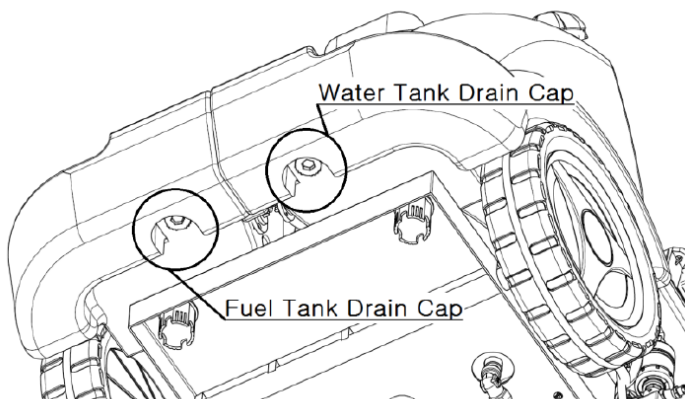

**D. Check the water and fuel filters routinely and replace as needed.**

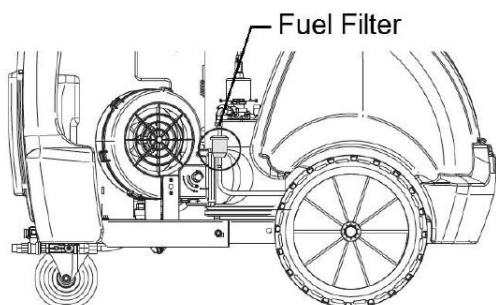
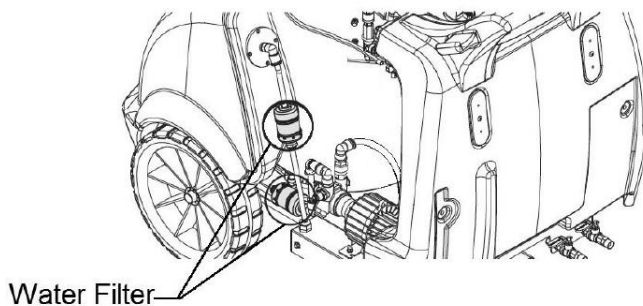

### E. Check/clean water probe sensors.

The steam unit has three water probe sensors (High, Com, Low). Scale build-up on the water probe sensors can affect sensor accuracy and will prevent the machine from operating abnormally.

**What you will need: screw driver (+), 14mm deep socket wrench, breaker bar (DO NOT USE A POWERED/TORQUED WRENCH!!!), sandpaper, and Teflon tape.**

#### Steps:

1. Unplug the electric cord and let the steam pressure drop to "0."
2. Cool down and drain the steam vessel by opening the drain valve.
3. Remove the top cover or open the lateral door and disconnect the sensors from wiring.
4. Remove the sensors from the vessel using 14mm deep socket wrench.
5. Using sandpaper, scrub the tip of sensors clean. Replace them if necessary.
6. Wrap the threads of the sensors with Teflon tape at least 6 times and insert the sensors by using tools.

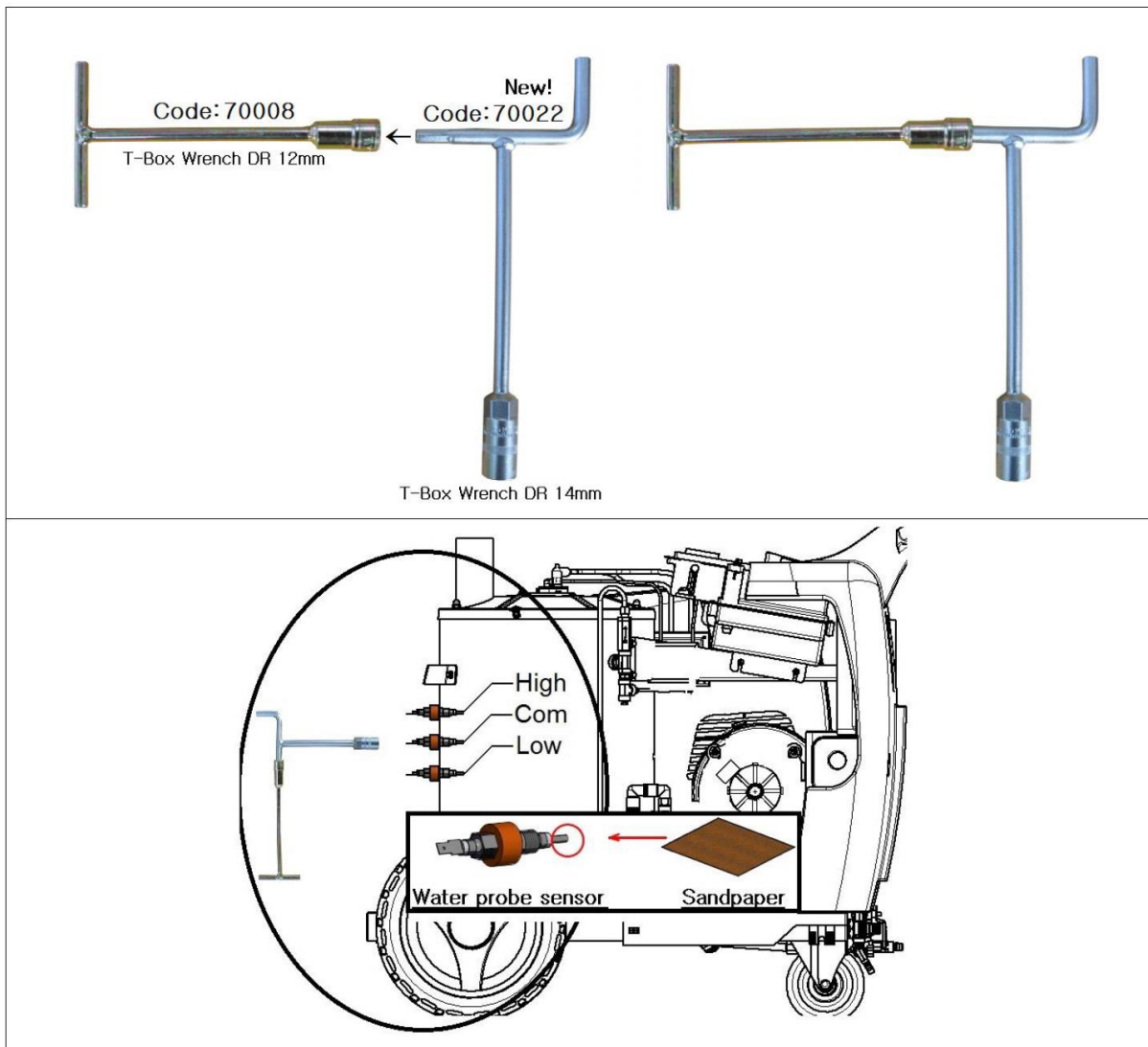

#### F. Clean / realign fuel nozzle and electrodes.

With the machine unplugged, clean the fuel nozzle and electrodes. Ensure correct spacing as shown below.

**What you will need: screw driver (+), dry towel, and ruler.**

##### Steps:

1. Disconnect H.V cables and fuel pipe from the top of the combustion chamber.
2. Remove the electrodes holder with a screw driver (+).
3. Clean the fuel nozzle and the two electrodes with a dry towel. Ensure correct spacing.

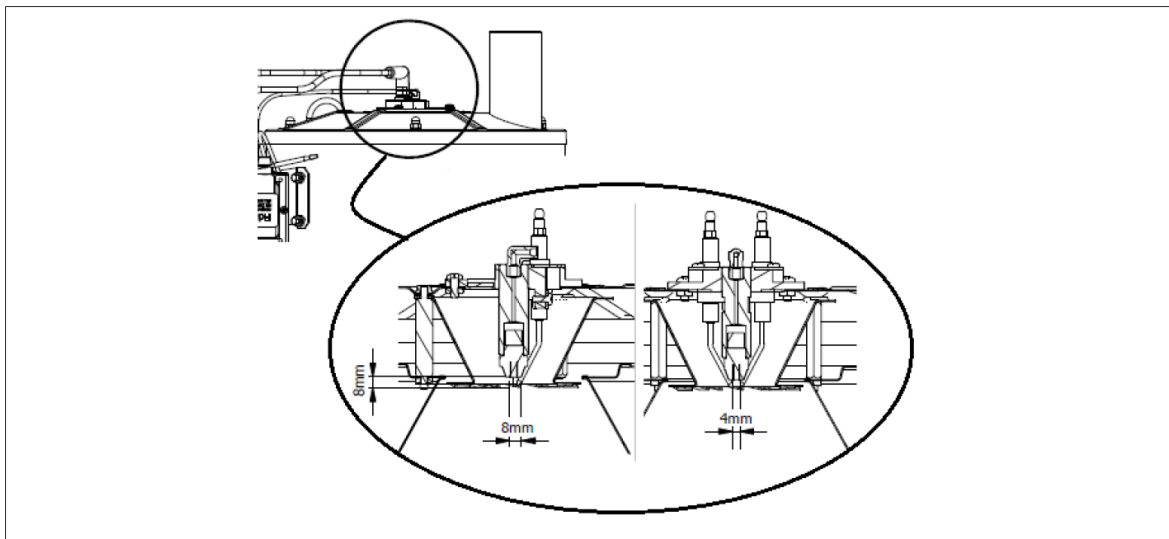

#### G. Perform the steam vessel de-scaling.

**What you will need: screw driver (+), wrenches, 10mm T-box wrench, container (10 liters or larger), 10 liters (2.5 gal) of diluted de-scaling liquid, and 2 liters (0.5 gal) of clean tap water.**

##### Steps:

1. Remove the top and lateral covers.
2. Open the drain valve and release all water from the vessel. Close the drain valve afterwards.
3. Disconnect the wiring from the high probe sensors.
4. Make sure the water tank is full or disconnect the wiring from the float switch.
5. Wear gloves and goggles and prepare descaling solution based on the instructions by the chemical supplier.
6. Detach the water suction line from the water filter and submerge the tip into the container.
7. Detach one of the steam hoses from the steam outlet and open the steam outlet valve.
8. Turn on the POWER (EMERGENCY STOP) switch then turn on STEAM switch to activate the water pump. Fill the vessel with 10 liters (2.5 gallons) of diluted de-scaling liquid.

9. Submerge the tip of the water suction line into the container filled with 2 liters (0.5 gallons) of clean tap water to wash out the water pump. Once water starts coming out of the steam outlet, turn off the STEAM switch.
10. Let the machine sit for the time instructed on the de-scaling liquid label. Do not exceed the recommended time to avoid steam vessel damage.
11. Drain the steam vessel by opening the Y-strainer drain cap and temporarily remove the strainer to prevent scale from clogging the line.
12. To wash out the steam vessel and lines, supply clean water to the steam outlet valve until you cannot see scale coming out of the Y-strainer.
13. Reassemble the Y-strainer and the water suction line and reconnect wires to the water probe sensors.

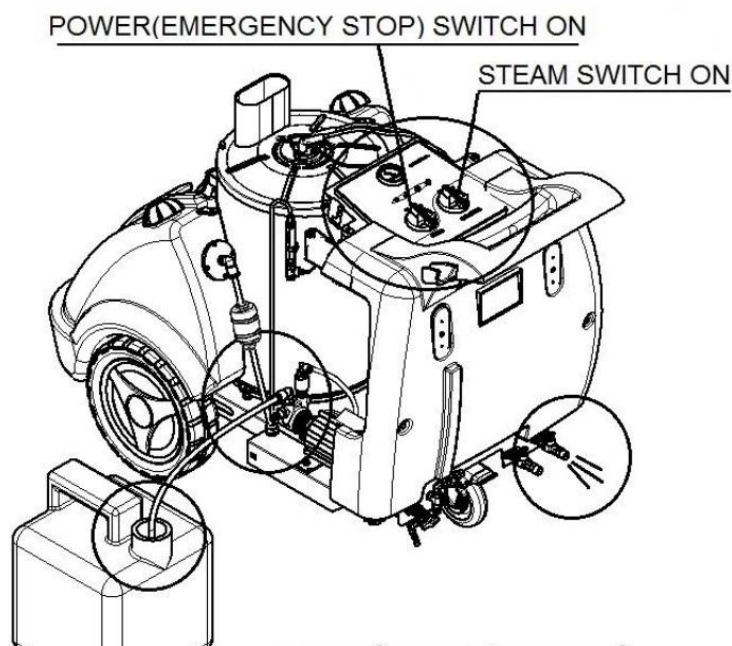
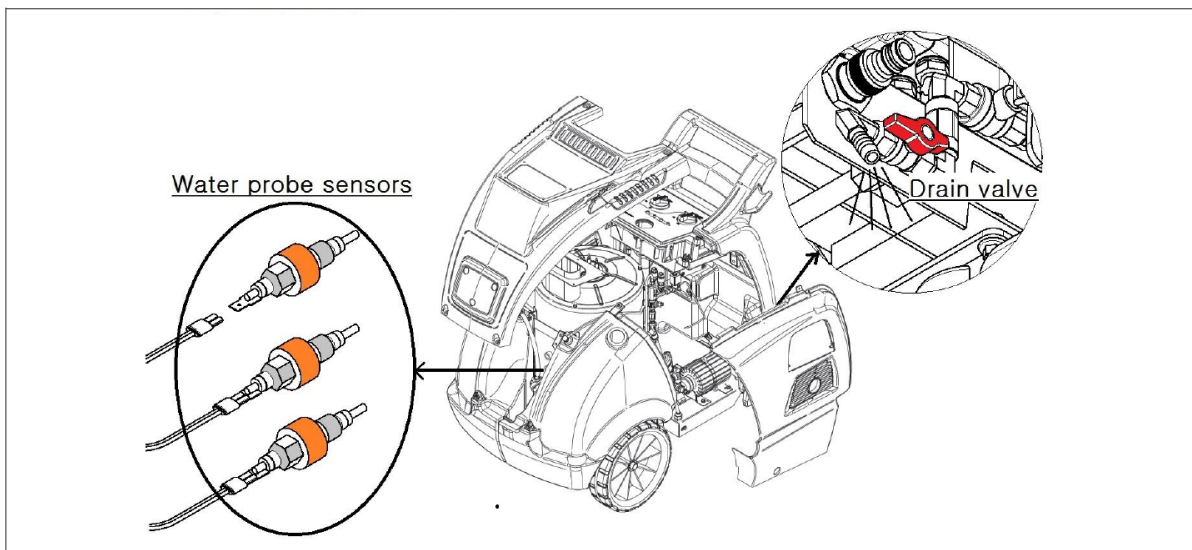

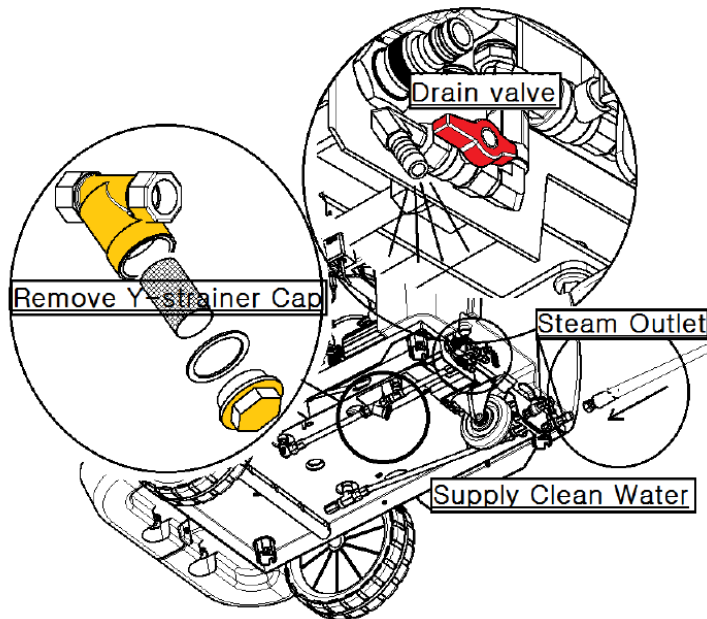

**Note!**

Check local regulations regarding the disposal of de-scaling liquid. Depending on the de-scaling product used, a special disposal method may be required.

**H. Remove soot in combustion chamber.**

***What you will need: screw driver (+), 10mm wrench, vacuum cleaner, towel and brush.***

**Steps:**

1. Remove all covers and disconnect the H.V cables and fuel pipe from top of the cylinder.
2. Unscrew the 3 bolts on the cylinder cover with 10mm wrench.
3. Open the cylinder cover and clean the steam vessel using a vacuum cleaner, towel, and brush.

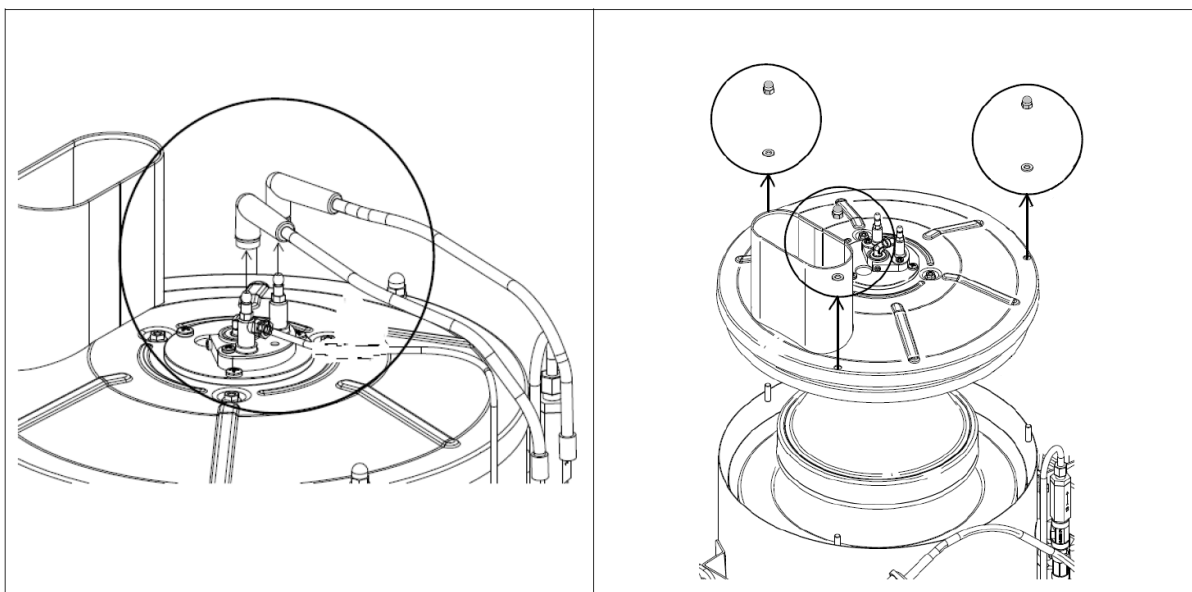

4. If more thorough cleaning is required, follow below additional steps.
  - a. Drain the steam vessel of all pressure and water.
  - b. Remove high, com, low water probe sensors and safety valve from the vessel.
  - c. Unscrew 4 fixed bolts and detach all of support brackets from control box
  - d. Detach a flexible intake hose from the cylinder.
  - e. Loosen the band located at the bottom of the cylinders. Lift up to remove inner and outer cylinders together.
  - f. Using a vacuum cleaner, clean both interior & exterior of the steam vessel.
  - g. If necessary, detach the steam vessel from the main chassis and wash with water. Let it dry completely before reassembling.

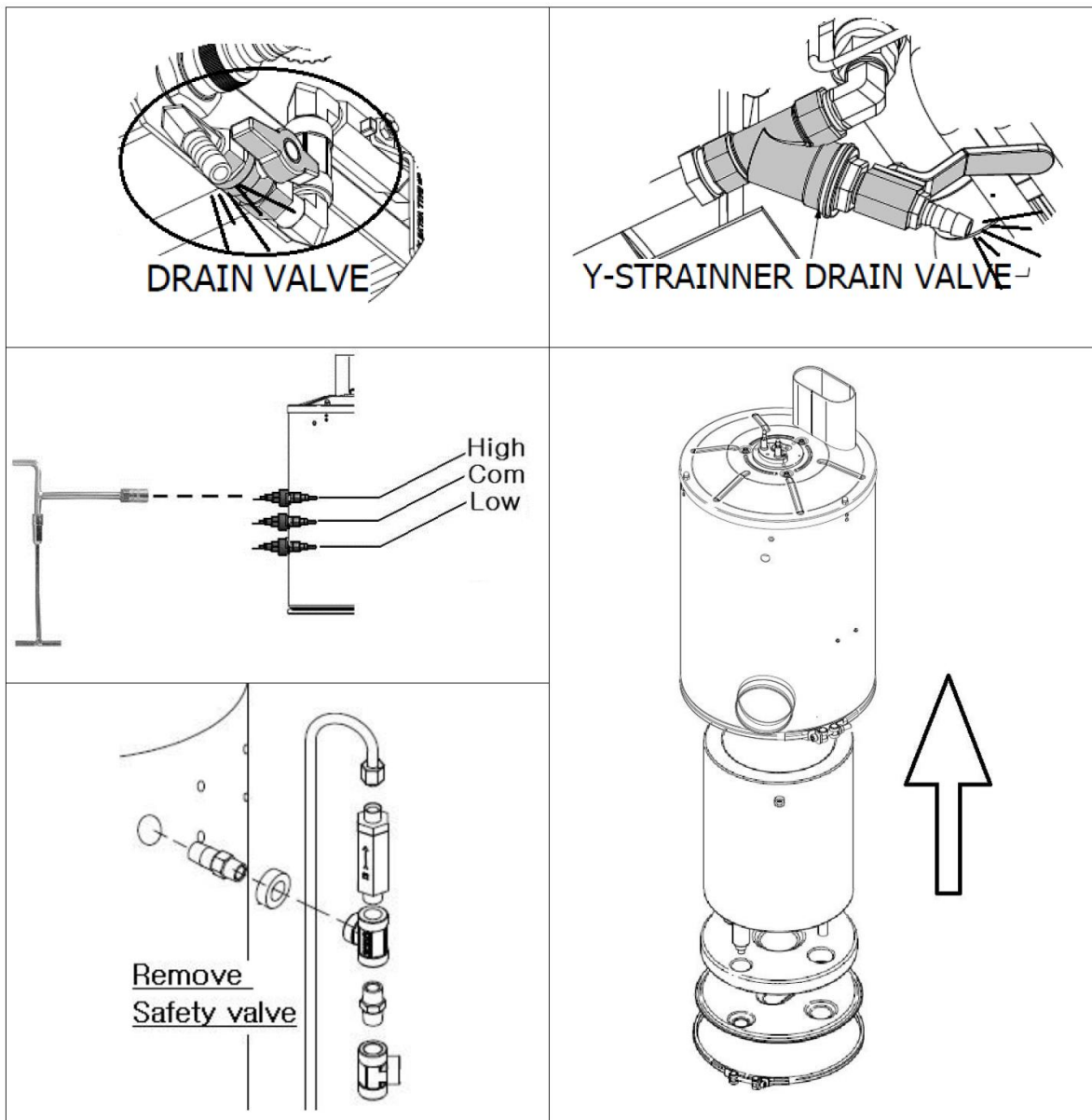

## Safety Features

The steam unit was designed with operator safety first in mind. There are multiple safety features that protect both the operator(s) and the steam unit. Understanding the safety features will enhance the user experience and assist you when troubleshooting.

### *The Main Safety Features:*

1. **Pressure control switch:** The pressure switch is permanently set on to both 8.5 bar (123.2 psi) and 9.5 bar (137.7 psi). The burner will shut off if the steam pressure exceeds the preset pressure on 8bar (123.2 psi) and will automatically reactivate when pressure decreases below 7 bar (101.5 psi). 9.5 bar (137.7 psi) pressure switch is for the safety device on emergency only.
2. **Thermistor & Air purge valve:** The temperature setting is between 90~100 °C (194 ~ 212° F). It controls the electronic valve for air purge. If the Thermistor reading is below the preset range, the machine will release air from inside the steam vessel at initial pressurizing stage. This will prevent any machine operation interference caused by false pressure reading due to internal air.
3. **Safety valve:** Pressure is released when steam pressure exceeds 9.5 bar (137.7 psi).
4. **The low water probe sensor:** The sensor prevents the vessel from heating without sufficient water in the steam vessel.
5. **Non-return valves:** Two non-return valves prevent steam from back drafting.
6. **Y-strainer:** The Y-strainer is connected to the steam drain. It is designed to break first before other important parts when a freeze rupture occurs.
7. **Water pump running time:** The water pump is programmed to shut off after running for 60 seconds (in normal operations) in order to avoid dry running.
8. **Programmed operation:** The intelligent system checks for the machines condition and takes necessary steps to prepare for the machine for a safe operation.

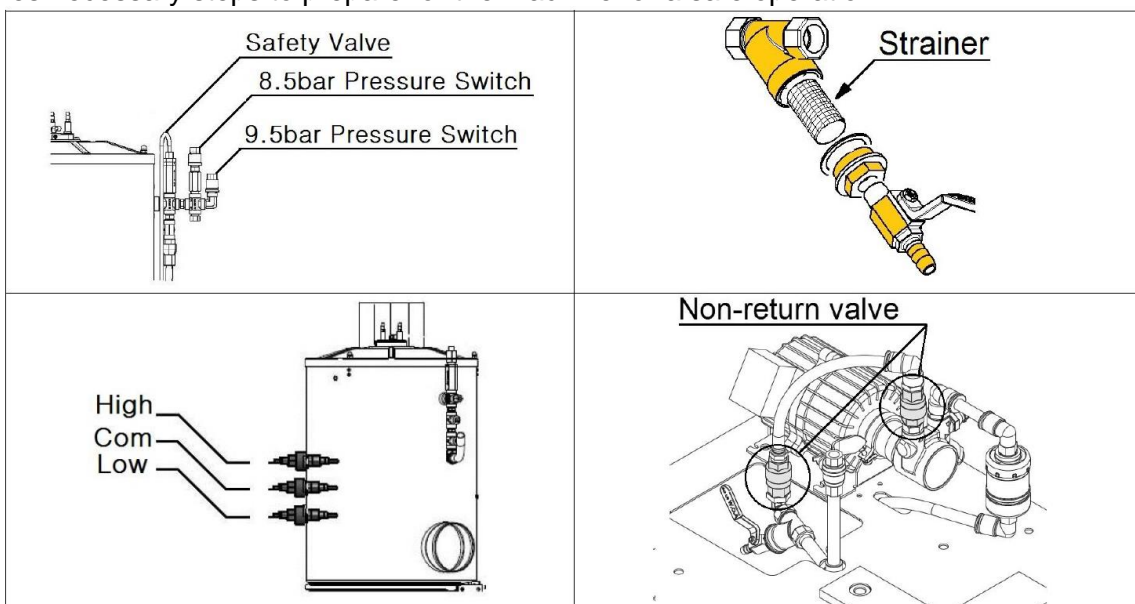

**Required Conditions to activate the ignition:**

1. The POWER (EMERGENCY STOP) and STEAM switches are on;
2. The float switches in the water and fuel tanks detect liquids;
3. The low water probe sensor in the vessel detects water;
4. The steam pressure should not be above 7 bar (101.5 psi); AND
5. The Blower fan, electrodes and electronic fuel pump are functioning.

**Required Conditions for the Water Pump to Activate:**

1. The POWER (EMERGENCY STOP) and STEAM switches are on;
2. Water is filled above the float switch level in the water tank;
3. Water is not detected by the high water probe sensor; AND
4. The water pump has not been running over 60 seconds during normal operation; OR
5. The water pump has not been running over 120 seconds at initial operation.

**Warning! When steam pressure arise above 8.5 bar (123.2 psi):**

When steam pressure gauge indicates above 8.5 bar (123.2 psi), you must turn off both STEAM and POWER (EMERGENCY STOP) switches; confirm the cause and take steps necessary before operating the machine again. (Refer to "Troubleshooting Guide" No. 10)

**Possible Cause(s):**

1. Identifying the cause of high pressure from fuel pump.

If the burner keeps igniting when the pressure gauge indicates pressure beyond 8.5bar (123.2 psi), turn the POWER (EMERGENCY STOP) switch off, and contact your distributor or manufacturer.

2. Identifying the cause of high pressure from water pump.











If the burner is off, and the pressure is above the maximum preset value, the most likely cause of the high pressure is compressed steam or water in the vessel. If overpressure persists, clean the high water probe sensor or replace if necessary (See "Maintenance" on page 15)

## Troubleshooting Guide



When a malfunction occurs, refer to the troubleshooting guide below. If the problem persists, please contact your local distributor and report the problem by referring to the reference number on the left hand side.

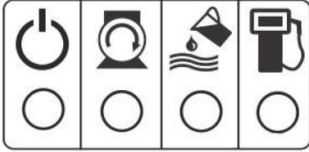
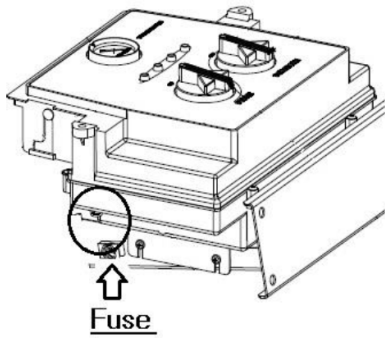
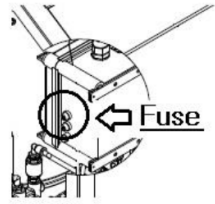

### LED Light Indication

○ off    ● (with sunburst) - Blinking    ● (solid) - Solid    ● (with vertical line) - Solid or off    [Speaker icon] - Alarm beeps once    [Speaker icon with wavy lines] - Alarm beeps continuously

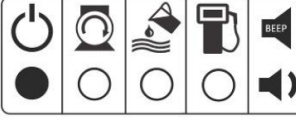
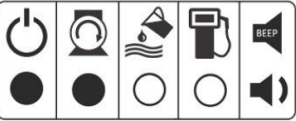
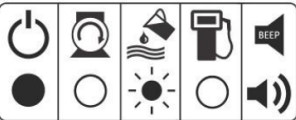
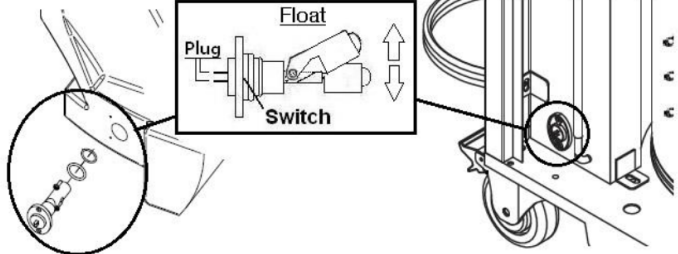
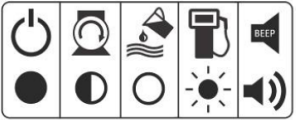
	Main power on.		Water pump over-run flashing
	Water pump run on.		Water tank level low flashing.
	Low water level detection error on.		Fuel tank level low flashing.
	Flame error on		Alarm beeps continuously
	Alarm beeps once.		Continuous pressure decrease.
			Continuous pressure increase over 8.5 bar (123.2 psi)

No.	Light & Alarm Indications	Description & Cause	
		Remedy	
1		No LED lights on and no alarm sound when POWER (EMERGENCY STOP) & STEAM switches are on due to;	
		1) No power supply (power plug disconnected) 2) Blown fuse	
		1) Check your electrical power source and power plug 2) Replace the fuse.	
			

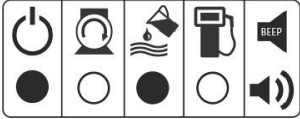
2		<p>The POWER (EMERGENCY STOP) and STEAM switches are on. The POWER light is on and the alarm beeps once.</p> <p>This is normal operating condition.</p>
3		<p>The POWER (EMERGENCY STOP) and STEAM switches are on. The POWER &amp; WATER PUMP RUN light are on, and the alarm beeps once.</p> <p>This is normal operating condition. The WATER PUMP RUN light will go off momentarily. (See page 9 “Initial Operation”)</p>
4		<p>Float switch is not detecting water in the water tank due to:</p> <ol style="list-style-type: none"> <li>1) Water shortage; OR</li> <li>2) Malfunction of the float switch in the tank.</li> </ol> <p>1) Add water to the water tank. 2) Disconnect the wire from the float switch. If the signal clears, replace the float switch.</p> 
5		<p>Float switch in the fuel tank is not detecting diesel fuel due to:</p> <ol style="list-style-type: none"> <li>1) Fuel shortage AND/OR</li> <li>2) Malfunction with the float switch in the tank.</li> </ol> <p>1) Add fuel to the fuel tank. 2) Disconnect the wire from the float switch. If the signal clears, replace the float switch. (Refer to Guide No.4 figure)</p>
6		<p>Water probe sensors (High, Com, Low) cannot detect water in the steam vessel because:</p> <ol style="list-style-type: none"> <li>1) Not enough water is present in the vessel; OR</li> <li>2) Water probe sensors(High, Com, Low) are malfunctioning due to scale build up.</li> </ol> <p>1) Wait until the pump refills the vessel. Once the alarm is deactivated, normal operation can resume. 2) Clean the water probe sensors. (Refer to Guide No.7 figure)</p>

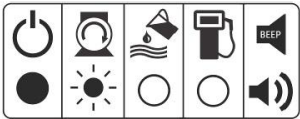
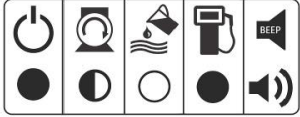
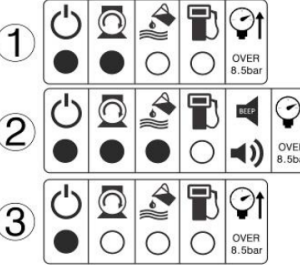
7		<p>The low water probe sensor cannot detect water in the steam vessel because:</p> <ol style="list-style-type: none"> <li>1) The low water probe sensor is defective; or</li> <li>2) The low water probe sensor's connection cable is disconnected; or</li> <li>3) The low water probe sensor cannot detect water due to scale built-up.</li> </ol> <p>1) Check the low probe sensor and replace it. 2) Check the connection cable. 3) Clean the low probe sensor with sandpaper and re-install</p>  <p><u>Water probe sensor</u>                      <u>Sandpaper</u></p>
8		<p>The water pump has run overtime:</p> <ol style="list-style-type: none"> <li>1) At initial operation, the water pump has a 120 seconds running time limit.</li> <li>2) Once low water probe sensor detects water, the water pump is programmed to run up to 60 seconds.</li> </ol> <p>1) Check for blockage in the water line. Clean or replace water filter, pipes and/or water pump. 2) Reset the STEAM switch.</p>
9		<p>There is a flame detector error (no ignition) due to:</p> <ol style="list-style-type: none"> <li>1) Fuel filter / Fuel pump performance degradation / Line is clogged.</li> <li>2) Malfunction of the Electrodes(Ignitor) or Blower Fan</li> <li>3) Interference of light to the sensor(day light, any light)</li> <li>4) Malfunction of the 8.5 bar (123.2 psi) pressure switch</li> </ol> <p>1) Check fuel filter &amp; fuel line if it is clogged or check fuel pump is malfunction. And then clean or replace if necessary. 2) Check electrodes, fuel nozzle, blower fan and adjust or replace if necessary. (Refer to Guide No.14~16 figure) 3) Check and seal the packing of the flame sensor. 4) Replace the 8.5 bar (123.2 psi) pressure switch.</p>
10		<p>The steam pressure arise above 8.5 bar (123.2 psi) due to:</p> <ol style="list-style-type: none"> <li>1) ~ 2) The water probe sensors are not detecting water and the water pump is running continuously.</li> <li>3) Pressure is over 8.5 bar (123.2 psi) and the burner is still on.</li> </ol> <p>1) ~ 2) Scale build-up is preventing water probe sensors from detecting water in the vessel → Clean or replace water probe sensors (High, Com, Low). 3) Check pressure switch. Then contact your distributor.</p>

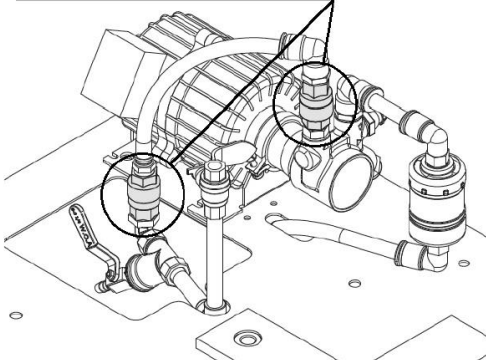
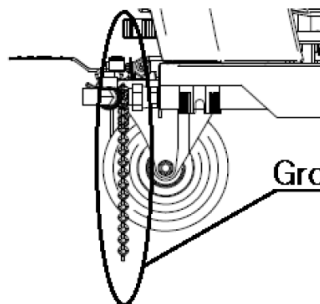
11	Water pump, water feed line or water tank becomes hot.	<p>1) Water or steam in the vessel traveled backwards into the water tank due to damaged non-return valves. 2) Steam comes out continuously from air purge valve into water tank.</p> <p>1) Clean or replace the non-return valves.</p> <p style="text-align: center;"><b>Non-return valve</b></p>  <p>2) Detach the air purge from the pipe line and clean it or check / replace thermistor.</p>
12	Water or steam is leaking from underneath the machine.	<p>1) Y-strainer has cracked due to freezing weather condition. 2) Safety valve bursts open due to overpressure in the vessel.</p> <p>1) Thaw the machine at room temperature. Inspect it for additional damages. Replace the damaged part(s) if any. (See "Freeze Prevention" on page 13) 2) If the safety valve bursts at below 8.5 bar (123.2 psi), replace the safety valve. <u>If the safety valve bursts at over 8.5 bar (123.2 psi), contact your distributor.</u></p>
13	Static electricity on the spray gun or the machine.	<p>The machine is not grounded properly. .</p> <p>Ensure that the machine is grounded using the grounding chain located at the rear bottom of the machine.</p> <p style="text-align: center;"><b>Grounding Chain</b></p> 

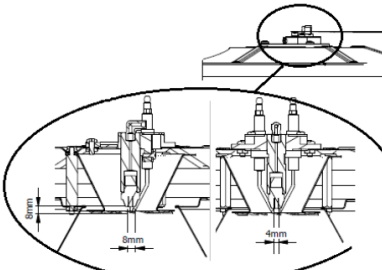
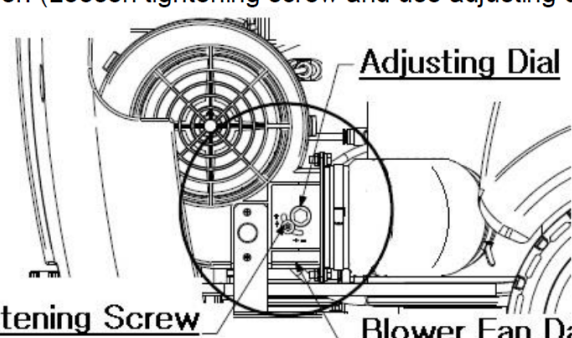
<p>14</p>	<p>White smoke from exhaust/flue.</p>	<p>Failed ignition or insufficient fuel amount for good combustion because;</p> <ol style="list-style-type: none"> <li>1) The mixture ratio of air &amp; fuel is not balanced (too much air); OR</li> <li>2) Ignition electrodes are malfunctioning; OR</li> <li>3) Defective fuel pump</li> </ol> <p>1) Check if the fuel filter needs to be replaced and clean all fuel lines.</p> <p>2) Clean or replace the ignition electrodes.</p> <p>3) Check the fuel pump and replace it if needed.</p> 
<p>15</p>	<p>Black smoke from exhaust/flue.</p>	<p>Insufficient oxygen (air) due to:</p> <ol style="list-style-type: none"> <li>1) Closed blower fan damper; OR</li> <li>2) The combustion chamber has built up too much soot.</li> </ol> <p>1) Increase the air intake on the blower fan by opening the damper. (Loosen tightening screw and use adjusting dial).</p>  <p>2) Loosen the band located at the bottom of the cylinders. Lift up to remove inner and outer cylinders together. Using a vacuum cleaner, clean the steam vessel. (See "Maintenance " on page 15)</p>
<p>16</p>	<p>Blower fan is not working.</p>	<p>Blower fan will be stopped in 30 seconds when detects every error.</p> <ol style="list-style-type: none"> <li>1) No Power supply or Blown up the fuse</li> <li>2) Fan motor is damaged</li> </ol> <p>1) Check the electrical Power source then replace the fuse. (Refer to Guide No.1 figure)</p> <p>2) Replace the fan motor.</p>

## BOILER ACCESSORIES

### Steam Pressure Hose

Connection between steam unit and steam mixing unit



1x 5 m  
with CAMLOCK coupling

### Steam Pressure Hose

Connection between steam mixing unit and steam adapter or inversion drum



1x 3 m  
with CAMLOCK coupling

## Steam / Air Mixing Unit



## Technical Service Request Form

Thank you for using our products.

When you encounter any problems using the steam unit, please fill out the form and email it to [info.boldan@trelleborg.com](mailto:info.boldan@trelleborg.com)

We will be in contact with you until the issue is resolved to your satisfaction.

No	Items that should be checked	Remark	
1	What is the serial number of the machine?		
2	Did you physically check water & fuel tank to see if they are filled?		
3	How many hours per day average do you operate your machine?		
<b>Continue to items below after the POWER (EMERGENCY STOP) and STEAM switches are on</b>			
4	Does the alarm beep continuously after STEAM switch is on?		
5	Please check 4 LED lights on the control panel box, and let us know indication of them as light on (LO), light flashing (BK) or off (OFF) in each blank below.		
	POWER Light (Green)	WATER PUMP RUN Light (White)	WATER TANK Light (Yellow)
6	Is there a sudden increase of the pressure gauge over 9.5bar (137.7psi)?		
7	Has any water exited from steam gun nozzle when pulling the gun trigger?		
8	Is there blowing air from the flue (Combustion chamber)?		
9	Is there a continuous crashing sound between Scroll and Impeller of the blower fan?		
10	Please distinguish the color of smoke if it occurs. Black – Dark Gray – Gray – White – Blue – Green or None (clear)		
11	Is the combustion chamber is still igniting even though STEAM switch is off?		
Company		Name	
E-mail		Phone	